

# Southern PRIDE

## SPECIFICATIONS MODEL SPK-500-SL



### COOKING CAPACITIES FOR THE SPK-500

Pork Butt (7lb.)	80 pieces	560 lb. total
St. Louis Ribs (2.75lb.)	75 pieces	206 lb. total
w/Optional Rib Racks	160 pieces	440 lb. total
Chicken (3lb.)	120 pieces	360 lb. total
Brisket (12lb.)	40 pieces	480 lb. total
Spare Ribs (3.5lb.)	60 pieces	210 lb. total

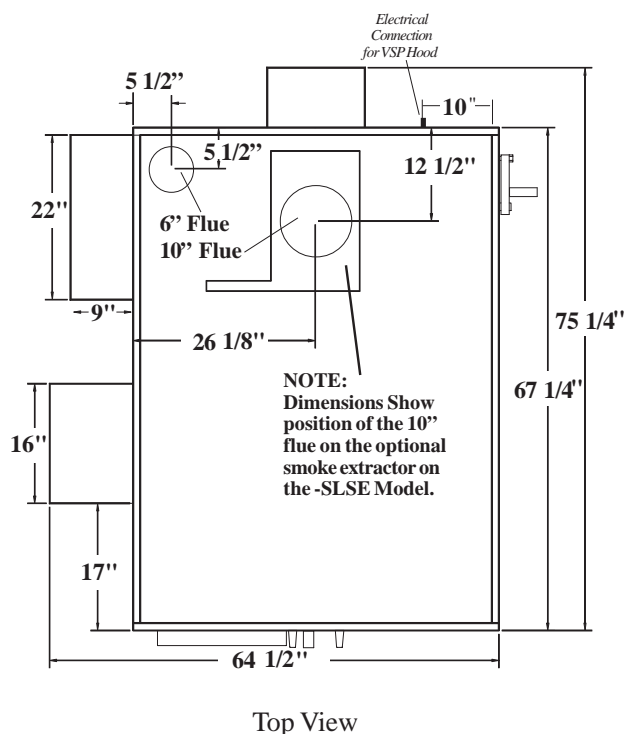
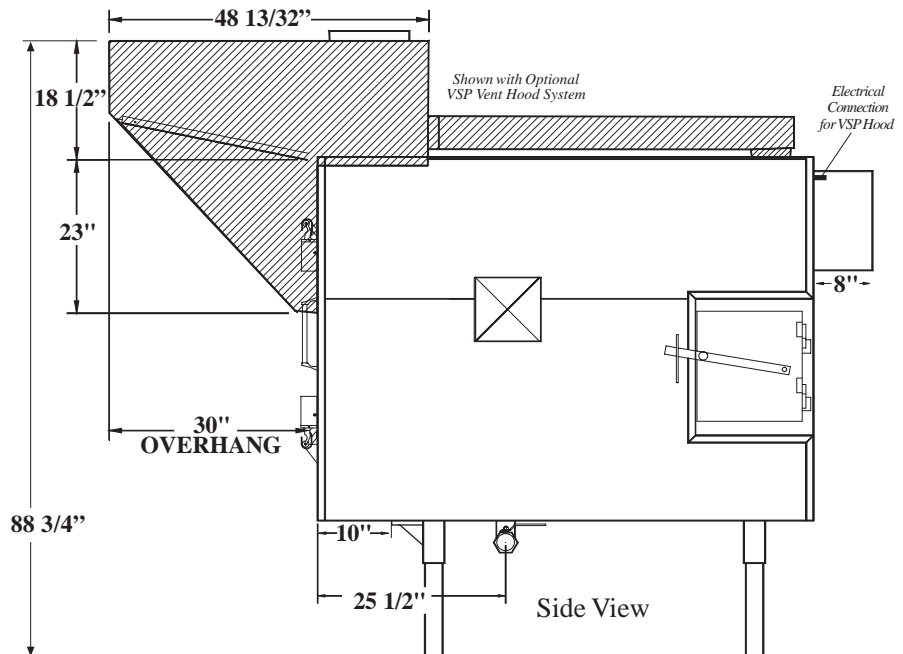
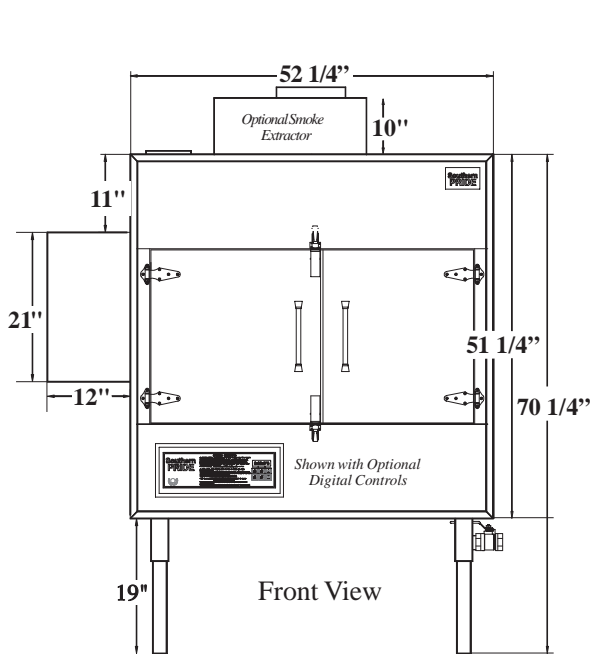

### SPK-500-SL

**Electrical Requirements:** 120 volts AC, 60 hertz, 1 phase, 15 amp wiring required.

**Gas Requirements:** 75,000 btu, 1/2 NPT

**Construction:** Inner Liner: 14 gauge H.R. Steel or 14 gauge Stainless Steel. Exterior: 22-gauge Polished Stainless Steel

**Firebox:** 10 ga. H.R. steel with 10 ga. H.R. firebox door. Uses wood logs or charcoal. Capacity: 2-3 logs 4-6" dia. 12-16" long.

**Dimensions:** 70 1/4" tall, 64 1/4" wide, 75 1/4" deep (including covers) w/19" legs

**Shell Dimensions:** 51 1/4" tall, 52 1/4" wide, 67 1/2" long.

**Food Racks:** Rotisserie with five (3) hanger racks, each with three (3) 12"x 42" food racks (15 Total). 52.5 Sq.Ft. of Cooking Surface. 3 1/2" Spacing between food racks.

**Air Circulation:** Low Velocity Convection Fan.

**Temperature Range:** 140-325 degrees F.

**Burner:** Electronic Pilot Gas Burner (Specify Natural or L.P. gas.)

**Shipping Weight:** 1,700 lbs.



**Approvals:** UL, ULC, NSF

**Venting:** See back page for venting instructions.

### VSPHOOD SYSTEM: Purchased through Southern Pride

VSPHOODS are U/L Listed to the applicable Southern Pride oven models and are NSF Certified.

#### HOOD SYSTEM TO INCLUDE:

1. Ventilation Hood
2. Two speed fan (1380/2000)
3. Curb with vented extension and hinge kit (Specify roof pitch)
4. Grease capture trough
5. Combustion chamber flue vent

#### SUPPLIED BY CUSTOMER:

6. Duct from hood to fan

**SPK-500-SL with recommended optional VSP Vent Hood System.**

**NOTE:** If you have a duct longer than 10 feet or an elbow in your duct installation, it may require a larger capacity exhaust fan. Please specify your duct requirements when ordering the VSP Hood System.

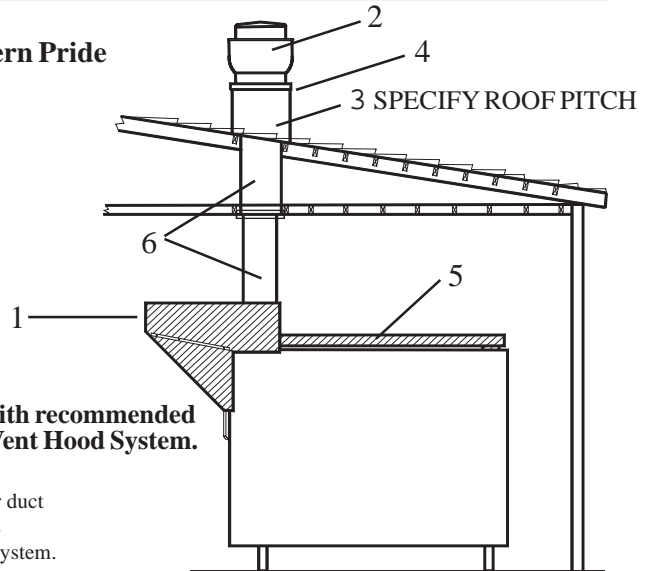

**ALL MODELS MAY ALSO BE INSTALLED UNDER A CANOPY HOOD RATED FOR COMMERCIAL COOKING APPLIANCES.**

*Note: The six inch all fuel chimney should extend at least 3' above the highest side of the roof opening and be at least 2' higher than any portion of the building within 10' horizontal*

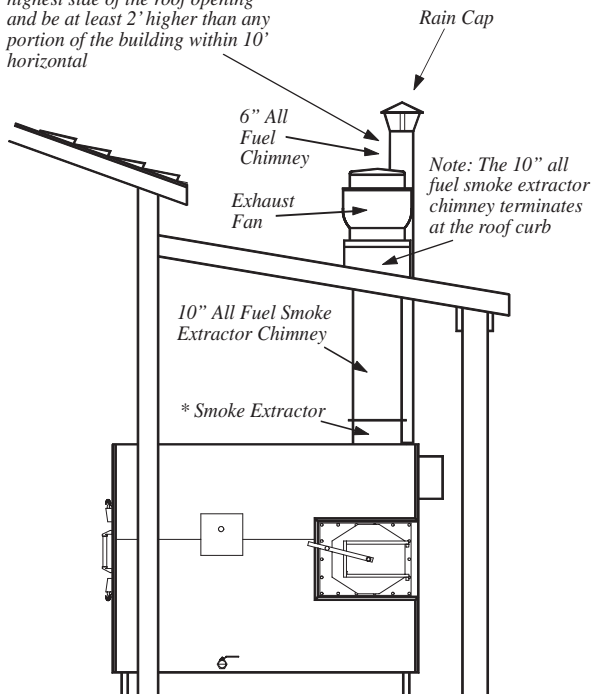

### THROUGH THE WALL - DIRECT VENT INSTALLATION

**NOTE 1.** When installing an Oven through a wall constructed of combustible material, use the **Southern Pride Insulation Kit** between the oven and the wall.

**2.** The room that the face of the oven is installed into should have a balanced or positive air pressure. If the room has negative air pressure, smoke could escape into the room during operation.

#### SUPPLIED BY SOUTHERN PRIDE: (\*)

Smoke Extractor Damper with 10" chimney adapter plate

#### SUPPLIED BY CUSTOMER:

6" All Fuel Chimney, 6" Rain Cap, and all accessories necessary for installation of the 6" chimney.

10" All Fuel Chimney, Exhaust Fan (NOTE: Fan must be listed for use as a commercial kitchen ventilator), fan curb, and all accessories necessary for installation of the smoke extractor system.

**The oven's minimum clearances from combustible materials** are 18" on left side, 24" on right, 18" on top, 48" from front, and 2" on back (although 10" on the back is recommended for servicing the unit). Minimum clearances are 18" to chimney connector and to smoke extractor chimney connector. Floor may be constructed of a combustible material. (Note: minimum clearance dimensions are from the oven cabinet, not from component cover.) (If provision is made for access to service, minimum clearance can be reduced to 2" on left side.) May be installed through a combustible wall with zero clearance with BBR kit No. 2099.

**ANY VENTILATION SYSTEM MUST BE INSTALLED IN ACCORDANCE WITH LOCAL CODES. CONSULT WITH LOCAL OFFICIALS AND A COMMERCIAL KITCHEN VENTILATION CONTRACTOR PRIOR TO INSTALLATION.**