

Southern PRIDE

SPECIFICATIONS MODEL SP-1000

Capacities on these products may vary based on physical shape, weight of product and the method of loading.

APPROXIMATE COOKING CAPACITIES

Pork Butt (7-8 lb. each).....	144 pieces
St. Louis Ribs (2.75 lb. each).....	96 pieces
Chicken (3-4 lb. each).....	216 pieces
Beef Brisket (11-13 lb. each).....	60 pieces
Spare Ribs (4-5 lb. each).....	60 pieces

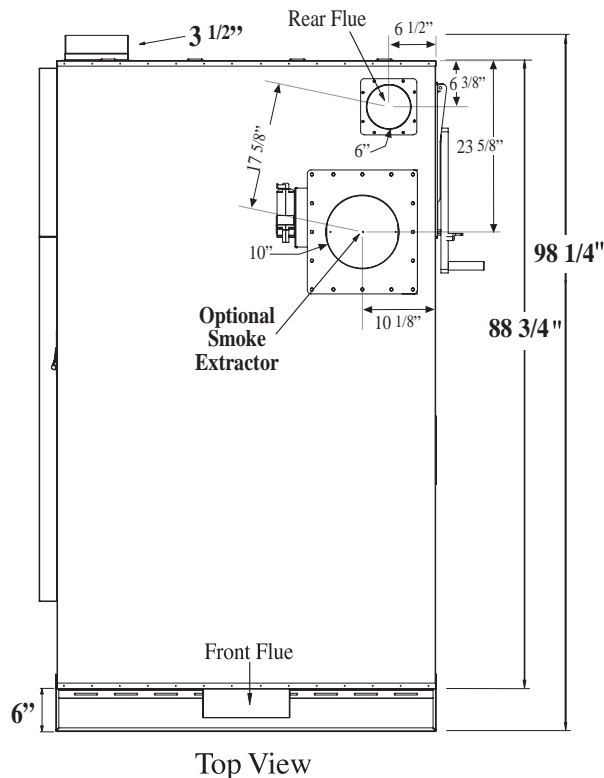
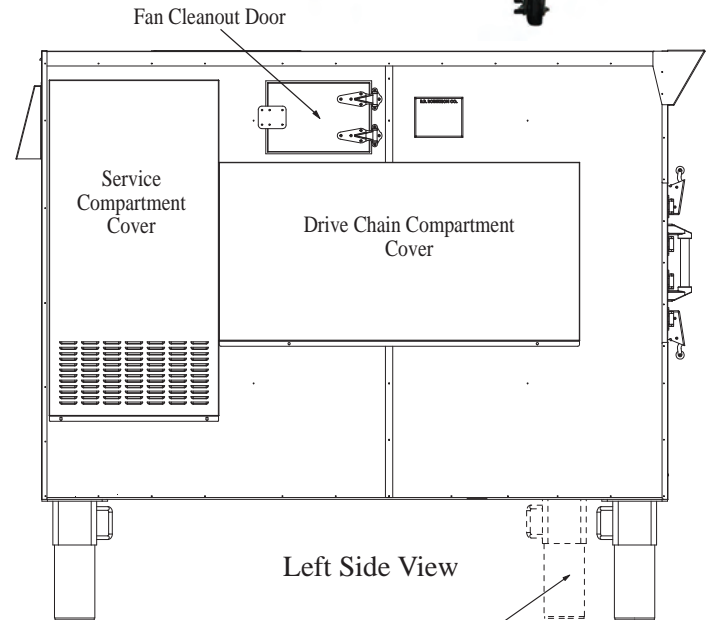
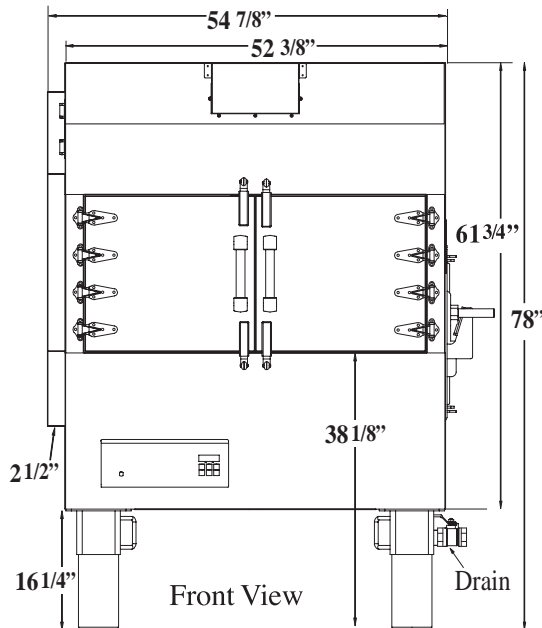

Electrical Requirements: 120 volts AC, 60 hertz, 1 phase, 20 amp wiring required.

Gas Requirements: 150,000 BTU, 1/2" NPT

Construction: Inner and Exterior Liner: 304 Commercial Grade Stainless Steel

Firebox: 1/4" thick H.R. steel, 1/4" thick firebox door. Uses wood logs or charcoal, 3-4 logs, 4-6" diameter, 12-16" long

Dimensions: 78" tall x 54 7/8" wide x 98 1/4" deep

Food Racks: Rotisserie with four (4) hanger racks, each with three (3) 18" x 42" food racks (12 total). 63 Sq.Ft. of cooking surface, 4 1/2" spacing between food racks.

Air Circulation: 2 speed Low Velocity Convection Fan.

Temperature Range: 140-350 degrees F.

Burner: Electronic Pilot Gas Burner (Specify Natural or L.P. gas)

Shipping Weight: 2,200 lbs.



Approvals: UL, ULC, UL EPH

Venting: Vent Hood Ready and Smoke Extractor Ready. See back side for venting instructions.

VSPHOOD SYSTEM: Purchased through Southern Pride

VSPHOODS are U/L Listed to the applicable Southern Pride oven models and are NSF Certified.

HOOD SYSTEM TO INCLUDE:

1. Ventilation Hood
2. Two speed fan (1380/2000)
3. Curb with vented extension and hinge kit (Specify roof pitch)
4. Grease capture trough

SUPPLIED BY CUSTOMER:

5. Duct from hood to fan

SP-1000 with recommended optional VSP Vent Hood System.

NOTE: If you have a duct longer than 10 feet or an elbow in your duct installation, it may require a larger capacity exhaust fan. Please specify your duct requirements when ordering the VSP Hood System.

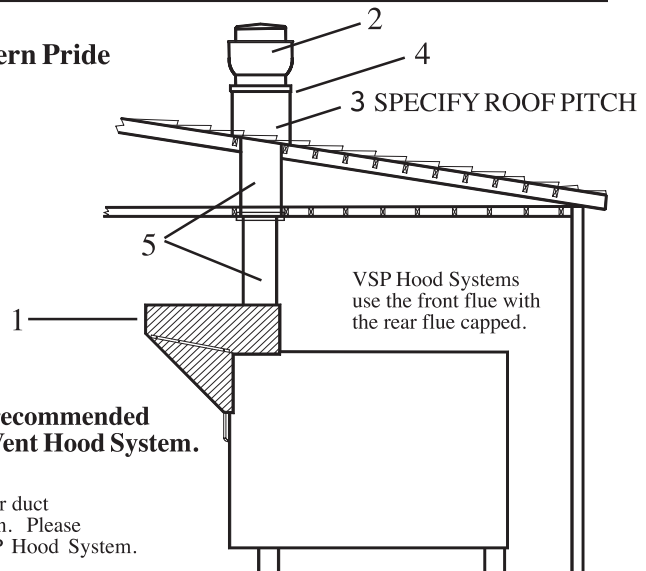

ALL MODELS MAY ALSO BE INSTALLED UNDER A CANOPY HOOD RATED FOR COMMERCIAL COOKING APPLIANCES.

Note: The six inch all fuel chimney should extend at least 3' above the highest side of the roof opening and be at least 2' higher than any portion of the building within 10' horizontal

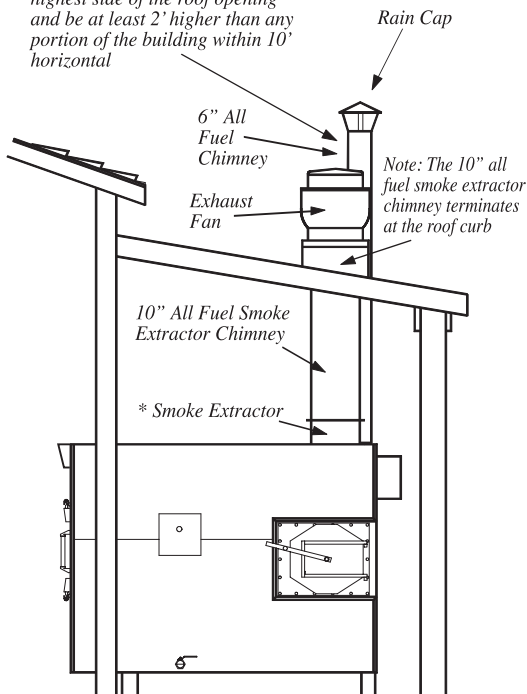

THROUGH THE WALL -DIRECT VENT INSTALLATION

1. When installing an oven through a wall constructed of combustible material, use the **Southern Pride Insulation Kit #2099** between the oven and the wall.
2. Hole Cut Out Note: When using Insulation Kit #2099, please note that the insulation board is 1" thick and is to be installed between the wall opening and each side and the top of the oven, no insulation is used between the wall and bottom of the oven. To accommodate the insulation add an additional 1" of clearance to the sides and top of the wall cut out size.

For ease of installation adding additional 1" of clearance on all sides for installing the oven into the cut out is also recommended. This would mean the cut out size would be increased by a total of 2" for each side and the top of the hole cut out and 1" to the bottom of it.

3. The room that the face of the oven is installed into should have a balanced or slightly positive air pressure. If the room has negative air pressure, smoke could escape into the room during operation.

Supplied by Customer: 6" all fuel chimney, 6" rain cap, and all accessories necessary for installation of the 6" chimney. 10" all fuel chimney, exhaust fan (Fan must be listed for use as a commercial kitchen ventilator), fan curb, and all accessories necessary for installation of the smoke extractor system.

The oven's minimum clearances from combustible materials are 18" on left side, 24" on right, 18" on top, 48" from front, and 2" on back. Minimum clearances are 18" to chimney connector and to smoke extractor chimney connector. Floor may be constructed of a combustible material. (Note: minimum clearance dimensions are from the oven cabinet, not from component cover.) (If provision is made for access to service, minimum clearance can be reduced to 2" on left side.) May be installed through a combustible wall with zero clearance with BBR kit No. 2099.

ANY VENTILATION SYSTEM MUST BE INSTALLED IN ACCORDANCE WITH LOCAL CODES. CONSULT WITH LOCAL OFFICIALS AND A COMMERCIAL KITCHEN VENTILATION CONTRACTOR PRIOR TO INSTALLATION.