

Southern PRIDE

WOOD BURNING BBQ PITS & SMOKERS

MODELS BBR 79-2 & BBR 79-3

INSTRUCTION MANUAL



BBR 79-2



BBR 79-3



**Southern
PRIDE**
Distributing, L.L.C.

5003 Meadowland Parkway - Marion, Illinois 62959-5892
PHONE: 618-997-9348 - FAX: 618-993-5960 - SALES: 800-851-8180
<http://www.southern-pride.com> - sales@sopride.com - service@sopride.com
SERVICE: 800-437-2679 - SERVICE FAX: 618-993-0378 - parts@sopride.com

CONGRATULATIONS

In selecting Southern Pride, you have chosen the finest, most advanced and most fully automatic wood burning barbecue pit available. With us, “ It’s Simply, a Matter of Pride”.

Please read this Instruction Manual carefully prior to installation and operation of your Southern Pride pit. Proper installation, operation, cleaning and maintenance are essential for your satisfaction and safe operation.

KEEP THIS MANUAL FOR REFERENCE

TABLE OF CONTENTS

Safety Information	3
Diagram of Controls & Components	4
Operating Instructions	6
Cleaning Instructions	7
Maintenance Schedule	7
Electrical Instructions	8
Oven Wiring Diagram	9
Items to check before firing Burner	11
Burner Specification & Instructions	12
Gas Piping Instructions.	13
Venting Instructions	14
Replacement Parts List	15
Warranty	16

SAFETY INFORMATION

FOR YOUR SAFETY

IF YOU SMELL GAS . . .

1. Open windows.
2. Do not touch electrical switches.
3. Extinguish any open flames.
4. Immediately call your gas supplier.

DO NOT STORE OR USE GASOLINE OR OTHER FLAMMABLE VAPORS OR LIQUIDS IN THE VICINITY OF THIS OR ANY OTHER APPLIANCES.

1. The pit area **MUST** be kept clear and free of combustible materials, gasoline and other flammable vapors and liquids.
2. The flow of combustion and ventilating air **MUST NOT** be obstructed from reaching the pit.
3. The frame of the unit **MUST** be electrically grounded at all times. See “Electrical Instructions”.
4. Caution should be used when opening and closing the Firebox Door. The door is **HOT** during operation.
5. **DO NOT** remove service compartment access panels when unit is in operation, or leave off during operation.
6. Gas burners require the services of an experienced mechanic for proper setting and adjustment. If the burner does not appear to be operating properly, **DO NOT ATTEMPT TO ADJUST THE BURNER YOURSELF**, but call in a competent serviceman or contact Southern Pride.
7. **DO NOT** allow unqualified personnel to perform service work or adjustments on this unit. To do so, will **VOID WARRANTY** and could result in a hazardous condition.
8. Be sure any new employees, who might operate the unit, are instructed on operation and safety information prior to operating the unit.
9. Caution: Ashes removed from the Firebox should be stored in a non-combustible container with a sealed lid only. Store ashes in a well ventilated area. **FUMES COULD BE HAZARDOUS.**
10. **WARNING : IT IS EXTREMELY IMPORTANT TO FOLLOW DAILY CLEANING INSTRUCTIONS. GREASE OR BUILDUP OF SOLIDS INSIDE THE PIT COULD RESULT IN A FIRE HAZARD.**
11. **KEEP THIS INSTRUCTION MANUAL FOR REFERENCE.**

SOUTHERN PRIDE'S BBR 79-2 & BBR 79-3 BBQ OVEN

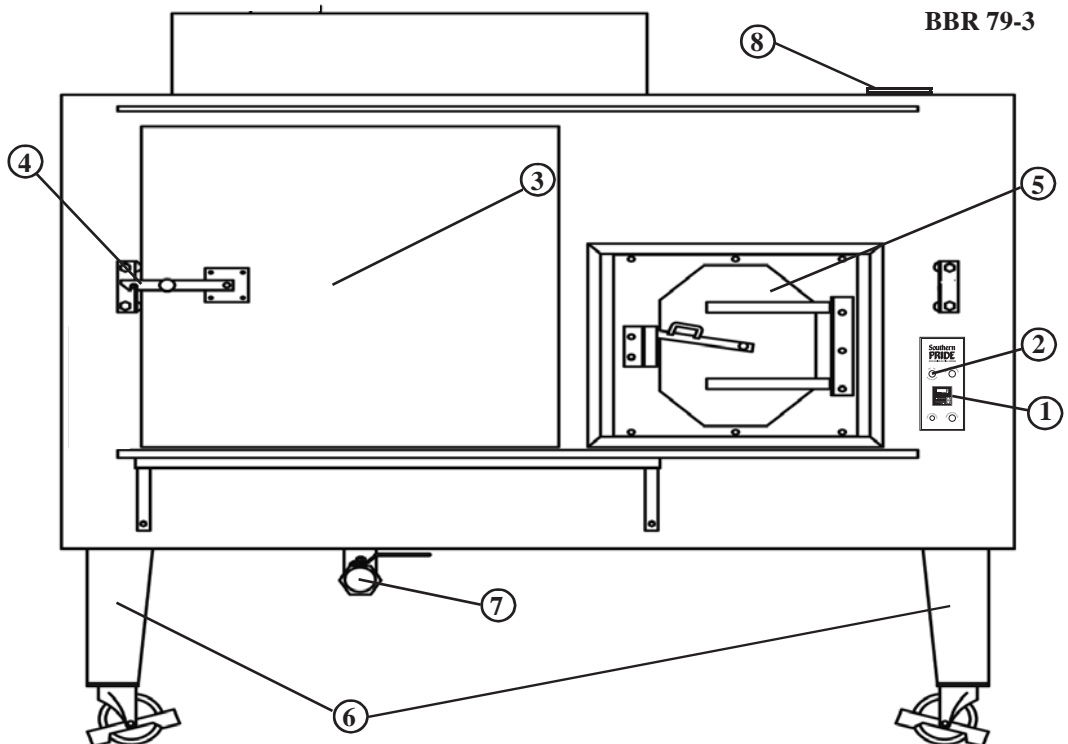
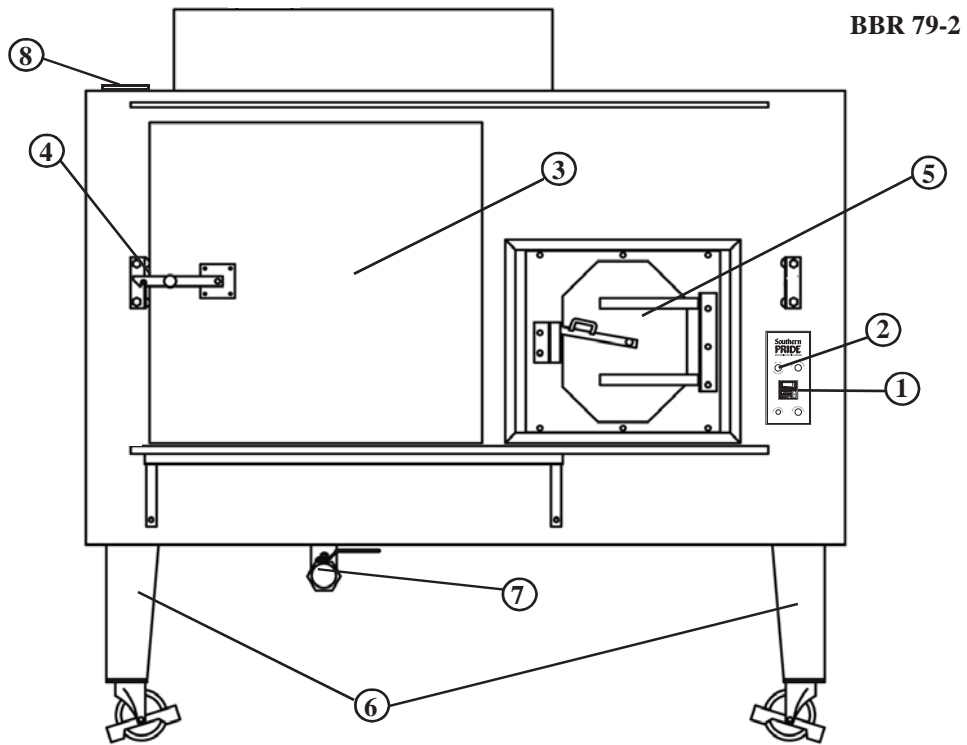

BBR 79-2 & BBR 79-3 CONTROLS AND COMPONENTS

- 1. CONTROL THERMOSTAT** - Adjustable temperature setting (140-325°F) with OFF position. Maintains desired Pit temperature by controlling the Gas Burner. This unit also provides current oven temperature display.
- 2. MAIN POWER SWITCH** - Activates the Rotisserie, Convection Fan, Thermostat, and Red Indicator Lamp. (The Red Indicator Lamp on the Main Power Switch indicates when the switch is ON.)
- 3. SLIDING MEAT LOADING DOOR** - For access to Racks and Pit interior.
- 4. MEAT LOADING DOOR LATCHES** - Latches apply positive pressure and seal doors.
- 5. FIREBOX DOOR** - Provides access for loading of wood in the Firebox Chamber.
- 6. CABINET LEGS** - Provide adjustment for leveling of the unit.
- 7. DRAIN VALVE** - Is opened after each cooking to drain grease.
- 8. FLUE COLLAR** - For connection of 6" Flue.

OPERATING INSTRUCTIONS

1. Load meat on the food racks.
2. Put a small amount of wood in the firebox. Use 2-3 logs, 4-6 inches in diameter, 12-15 inches long. Use green or slightly seasoned hardwoods only.

CAUTION

DO NOT USE DRY WOOD OR KINDLING.

DO NOT OVERLOAD FIREBOX. TOO MUCH WOOD CAN CAUSE OVERHEATING OF THE PIT.

COALS AND ASHES FROM PREVIOUS COOKING MUST BE REMOVED BEFORE LOADING WOOD.

DO NOT ALLOW ASHES IN OR NEAR THE BURNER OPENING. KEEP ALL LOGS AT LEAST 6 INCHES FROM THE BURNER.

Use Ash Scraper to aid in the removal of ashes.



Correct way to load wood.



3. Be sure the Meat Loading Door is secured in the closed position.
4. Turn the Main Power Switch to the ON position. The wood will be ignited and the cooking temperature will be maintained automatically.
5. Set the Thermostat to the desired temperature setting.
6. When the meat is cooked, turn the Main Power Switch to the off position and unload the racks.

Be sure the Meat Loading Door is secured in the closed position immediately following a cooking, and non-use periods.

CLEANING INSTRUCTIONS

1. Remove ashes and coals from Firebox after each cooking.

Ash Disposal: Ashes should be placed in a non-combustible container with a tight fitting lid. The closed container of ashes should be placed on a non-combustible floor well away from all combustible material, pending final disposal.

Use Ash Scraper to aid in the removal of ashes and coals from the Firebox.

Place ashes and coals in a non-combustible container with a tight fitting lid. Place container outside well away from all combustible material.

CAUTION: Fumes could be hazardous.



2. Drain grease. (Be sure hot coals and wood are removed from the Firebox before opening drain valve.)

Open Drain Valve and drain Grease.

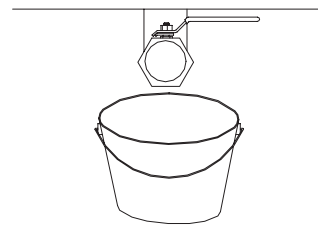

3. Remove food racks and clean them thoroughly. (Racks simply lift out of the brackets.)
4. Thoroughly clean the complete interior of the pit. Use a food service degreaser. Spray degreaser on the interior of the pit and allow it to set for 5-10 minutes. Rinse thoroughly with a water hose or pressure washer. Drain through the Drain Valve.

WARNING

IT IS EXTREMELY IMPORTANT TO FOLLOW THE ABOVE **DAILY** CLEANING PROCEDURES. GREASE OR BUILDUP OF SOLIDS INSIDE THE PIT COULD RESULT IN A **FIRE HAZARD**.

MAINTENANCE SCHEDULE

WEEKLY

1. Inspect Burner Head for accumulation of ashes and creosote. Clean as needed.
2. Inspect Convection Fan Blade for solids buildup or out of balance condition. Clean or replace as needed.
3. Inspect Meat Loading and Firebox Door Gaskets. Replace if damaged or leaking.

ELECTRICAL INSTRUCTIONS

ELECTRICAL REQUIREMENTS:

120 Volts A.C., 60 hz.,
2 wire, single phase,
15 amp wiring required.

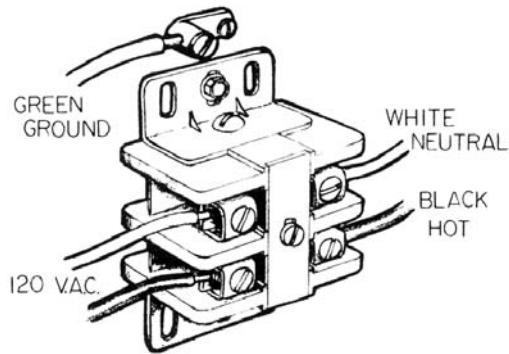

WARNING:

**CHASSIS MUST BE GROUNDED TO PREVENT POSSIBLE SHOCK HAZARD.
DO NOT ASSUME A PLUMBING LINE WILL PROVIDE SUCH A GROUND.**

WARRANTY IS VOID IF UNIT IS CONNECTED TO ANY VOLTAGE OTHER THAN SPECIFIED ABOVE AND ON NAMEPLATE.

1. Electrician must provide the conduit and wire for hookup.
2. Power is to be left **OFF** throughout installation.
3. Electrical Service is connected to the Terminal Block in the lower right side of the service compartment.
4. If venting or gas connections are to be done later, be sure that power is **OFF**.

DIGITAL GAS OVEN WIRING DIAGRAM BBR 79-2 and BBR-79-3

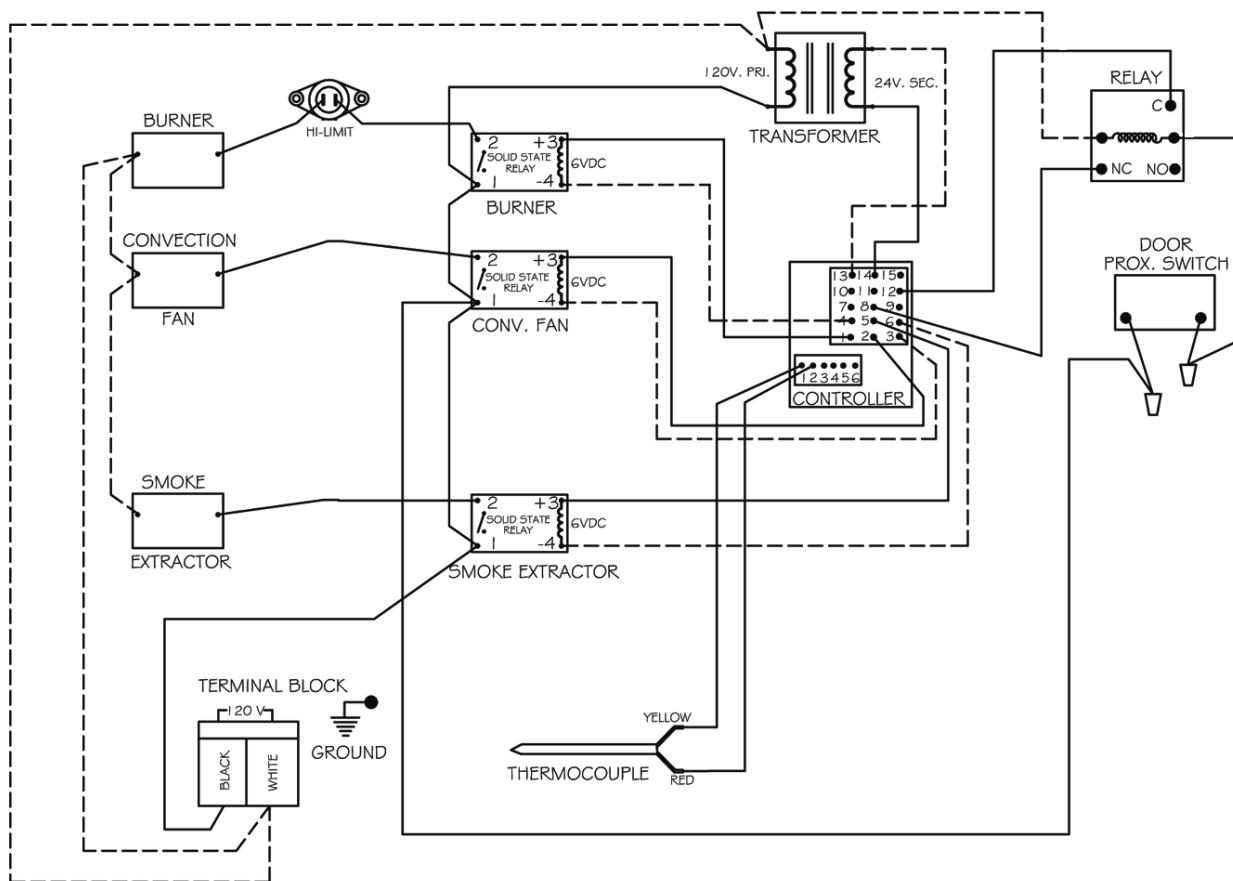

79-2 & 79-3 GAS OVEN WIRING DIAGRAM with CV Series Controller

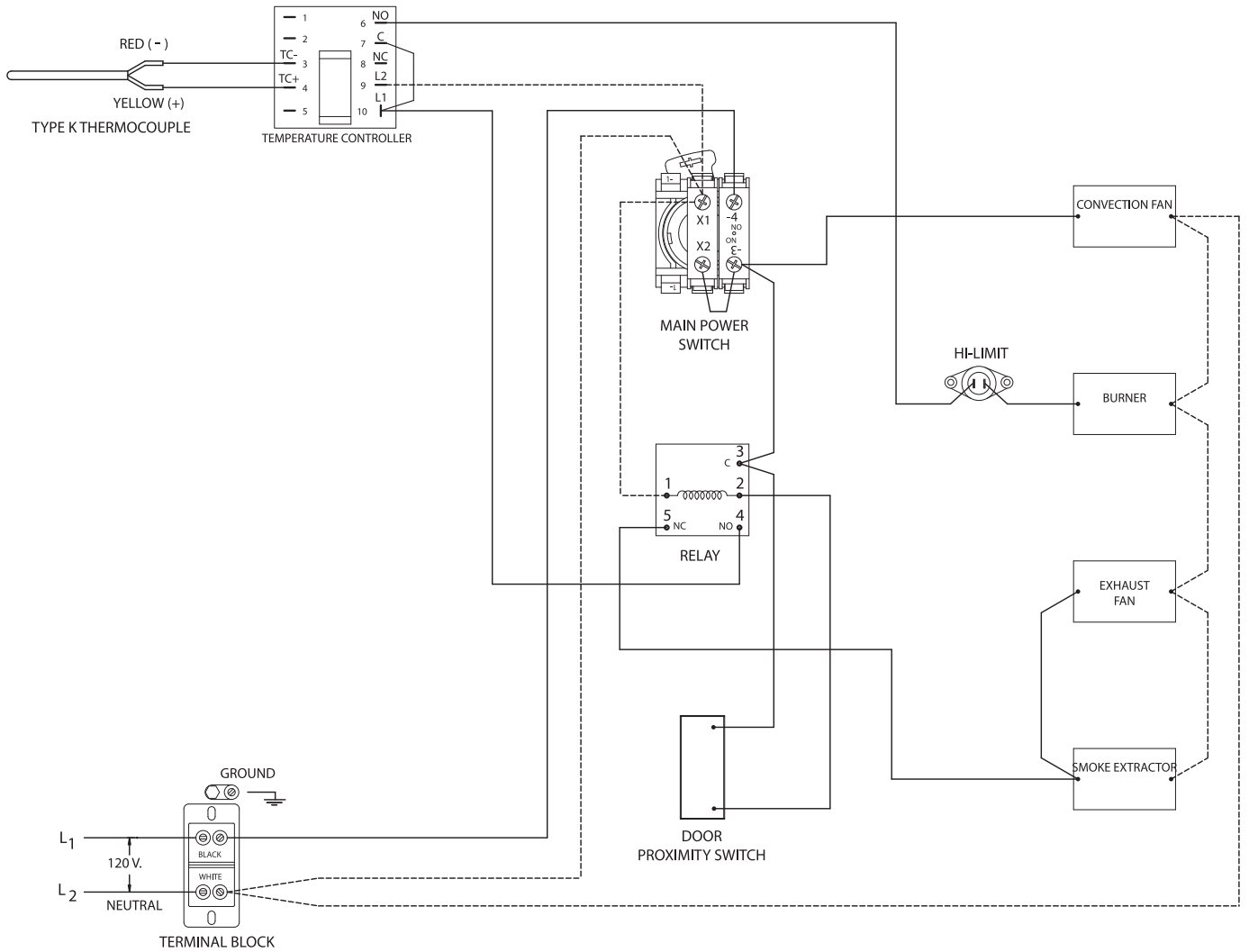

ITEMS TO CHECK BEFORE FIRING BURNER

IMPORTANT

WARNING: IMPROPER GAS HOOKUP WILL VOID WARRANTY AND COULD RESULT IN A HAZARDOUS CONDITION.

1. Gas line **MUST** be installed by a competent technician, and in accordance with this Manual.
2. Gas line **MUST** include an easily accessible manual shutoff valve, drip leg, and pressure gauge port.
3. Gas pipe size **MUST** be in accordance with the Pipe Capacity Chart in this Manual.
4. Gas line **MUST** be tested for leaks under pressure.
5. Gas Line **MUST** be purged to remove any air in the system.
6. Gas line pressure **MUST** be checked and **MUST NOT** exceed the maximum pressure specified in the Burner Specifications in this Manual.
7. Burner Orifice **MUST** correlate with the type of gas being supplied, as specified in the Burner Specifications in this Manual.

GAS PIPING INSTRUCTIONS

1. **READ ALL GAS PIPING INSTRUCTIONS CAREFULLY BEFORE MAKING GAS CONNECTIONS.**

WARNING: IMPROPER GAS HOOKUP WILL VOID WARRANTY AND COULD RESULT IN HAZARDOUS CONDITION.

2. Connect the gas line to the 1/2 inch piping that extends from the Gas Burner. A 1/2 inch N.P.T. fitting is required.

NOTE: All piping must comply with local codes and ordinances of the National Gas Code ANSI Z 223.1 - and NFPA #54.

3. The gas line should be a separate supply directly from the meter to the Burner. It is recommended that a new pipe be used and located so that a minimum amount of work will be required in future servicing. The piping should be so installed as to be durable, substantial, and gas tight. It should be free from cutting burrs and defects in structure and threading. Cast iron fittings or aluminum tubing should not be used for the main gas circuit. Joint compounds (pipe dope) should be used sparingly on male threads only and be approved for all gases.

NOTE: The building structure should not be weakened by installation of the gas piping. The piping should not be supported by other piping, but should be firmly supported by pipe hooks, straps, bands, or hangers. Butt or lap welded pipe should not be bent.

4. The Pipe Capacity Chart must be used to determine the size pipe to use from the meter to the Burner.

PIPE SIZE	PIPE CAPACITY CHART	
	MAXIMUM LENGTH FT.	
	NAT.	L.P.
3/8	-	10
1/2	10	30
3/4	70	150
1	200	250
1 1/4	250	-

FOR GAS PRESSURE OF 0.5 PSIG OR LESS BASED ON A 0.6 AND 1.5 SPECIFIC GRAVITY GAS.

5. **TEST PIPING FOR LEAKS.** Before turning gas under pressure into piping, all openings from which gas can escape must be closed. Immediately after turning on gas, the system should be checked for leaks. This can be done by watching the 1/2 cubic foot test dial for 5 minutes to show any movement, or by soaping each pipe connection and watching for bubbles. If a leak is found, make the necessary repairs and repeat the above test.

NOTE: Defective pipes or fittings should be replaced and not repaired. Never use a flame or fire of any form to locate gas leaks; use a soap solution.

6. After the piping and meter have been checked completely, **PURGE THE SYSTEM OF AIR. DO NOT** bleed the air inside the unit. Be sure to relight all the gas pilots on other appliances.

NOTE: The burner and its individual shutoff valve must be disconnected from the gas supply piping system during any pressure testing at excess of 1/2 psig.

VENTING INSTRUCTIONS

1. The model BBR 79-2SSE and the BBR 79-3SSE must be vented under a hood that meets the requirements of NFPA 96—Standard for Ventilation Control and Fire Protection of Commercial Cooking Operations.

Note: It is recommended that the local code officials and your contractor be consulted regarding local codes covering wood burning and gas operated appliances before installation.

2. Provisions must be made for adequate air supply for the pit. If the pit is to be installed in a sealed room or building utilizing exhaust fans, the room must be supplied with a return air system to eliminate negative air pressure in the room or building. Return air must be equal to or in excess of the exhausted air.
3. Pit must be level for proper grease drainage.
4. Minimum spacings to combustible materials:

Back—2”

Right side—18” (access for service)

Left side—2”

Top—18”

Front—36” (access for loading and unloading)

Chimney Connector—18”

Floor—May be combustible material

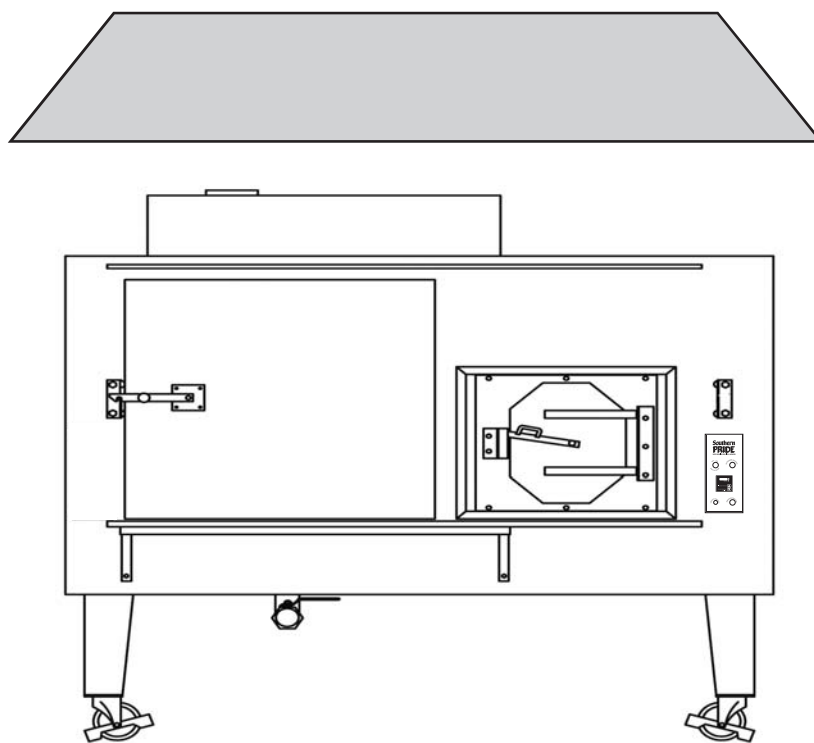

BBR 79-2 & BBR 79-3 REPLACEMENT PARTS LIST

PART NO.	DESCRIPTION
1002	CV Control Thermostat/Thermometer
1004	Bi Metal High Limit
1040	Convection Fan Motor
1041	Gas Burner
1060	Smoke Extractor Motor
1062	Transformer (Gas Burner Part)
1070	Motor Switch Relay (Gas Burner Part)
1076	Blower Motor (Gas Burner Part)
1080C	Main Power Switch
1084	Gas Valve (Specify Natural or L.P. Gas)
1085	EP Electrode
1086	High Voltage Lead
1087	Control Module (Gas Burner Part)
1090	Digital Control (Optional)
1092	10 AMP Solid State Relay (Optional)
1098-2	2' Type K Thermocouple
2004-1	Food Rack 12" x 60" BBR 79-3
2010	Food Rack 18" x 60" BBR 79-3
2029	Firebox Door Gasket
2180	Food Rack 12" x 42" BBR 79-2
2188	Food Rack 18" x 42" BBR 79-2
2426	8" Cooling Fan Blade (outside)
2428-L	10" Smoke Fan Blade (inside)
2452	Gas Regulator
2467	2" Ball Valve (Grease Drain)
4176G	Door Gasket BBR 79-3
4186G	Door Gasket BBR 79-2

**ONE YEAR LIMITED WARRANTY
(CONSULT FACTORY FOR DETAILS)
90 DAY LABOR WARRANTY (PRE AUTHORIZED)**

Southern Pride guarantees all new equipment of its manufacture to be free of defects in material and factory workmanship for a period of one year provided that the equipment is installed in the Continental United States, Alaska, or Hawaii and operated according to the Owner's Manual while located at the original address of installation, the Warranty Registration Card has been completed and returned to the factory within fifteen (15) days after installation, and a start-up has been performed by an authorized service agent.

Southern Pride's obligation under this warranty is limited to one of the following options with the option applicable to be selected by Southern Pride at the sole discretion of Southern Pride.

1. Owner is to return part, freight PREPAID. Southern Pride is to repair it at own expense if defective, and ship part back to owner freight collect.
2. Southern Pride is to furnish replacement part, freight collect, without requesting return of the defective part.
3. Southern Pride is to furnish replacement part, freight collect, in exchange for return of the defective part, freight collect.

Under certain circumstances, Southern Pride will reimburse owner for limited labor costs in replacing parts during a period of not more than ninety (90) days after installation, **(provided that work is authorized prior to being done and confirmed by Southern Pride's Service Manager.)**

Because Southern Pride does not and cannot control the owner's installation, use and maintenance of equipment manufactured by Southern Pride, this warranty does not cover: any equipment installed improperly; any equipment calibrated after start-up and acceptance; any component disassembled in the field, damage due to improper cleaning, i.e. burner (hosing or "watering down" machines will cause electrical failures not covered by warranty); blown fuses, light bulbs, gaskets, electric elements and accessory components not installed or manufactured by Southern Pride. Shipping damage must be reported to the carrier and is not covered under this warranty.

Southern Pride will not be liable for damage as a result of improper installation, misuse, abuse, alteration of original design, incorrect voltage, **unauthorized service**, or breakage of fragile items. Southern Pride will not be liable for any loss or consequential damage or expense accruing directly or indirectly from the use of equipment covered by this warranty, including any production or product losses or other damages which may occur as a result of equipment malfunction or failure. This warranty does not cover cooking performance, which is a function of food types, textures, temperatures and other variables chosen by the owner and over which Southern Pride has no control. The effect of corrosion, fire and normal wear on the equipment or component parts is not covered by this warranty. This warranty does not apply to damage caused by accident or to damage caused by the negligence of the owner and the employees of the owner, or to damage caused by lightning generated electrical current or any other Act of God whatsoever. This warranty does not apply to any equipment bearing a serial number which has been tampered with or altered.

This warranty is exclusive and is in lieu of all other warranties, express or implied, including any implied warranty or merchantability or fitness for particular purpose, each of which is hereby expressly disclaimed. The remedies described above are exclusive, and, in no event shall Southern Pride be liable for special, consequential or incidental damages for the breach or delay in performance of warranty.

TERMS AND CONDITIONS

For purposes of definition and interpretation, the term "Seller" as used herein refers to Southern Pride, and the term "Buyer" refers to the originator of a specific purchase order to Southern Pride.

Possession of a price list does not necessarily constitute an offer to sell by Southern Pride. Prices and specifications are subject to change without notice. All items will be invoiced at prices in effect at time of shipment. Equipment prices do not include federal, state, city or local taxes which may apply, and all sales are subject thereto. No order, whether written or oral, shall result in a contract, unless it is accepted and acknowledged in writing by Seller at Seller's office in Marion, Illinois.

Shipping weights are approximate and all prices are quoted F.O.B. Marion, Illinois. All "common carrier" shipped equipment shall be domestic crated; all others shall be uncrated and subject to delivery charge per zone chart. Any equipment held for shipment upon Buyer's request beyond the delivery date specified on original purchase order, will be due and payable within terms and will result in storage charges.

Delivery estimates are figured from date written orders are received and accepted by Seller. Seller will meet Buyer's delivery request as nearly as possible but does not guarantee shipment nor delivery on any particular date. Seller reserves the right to ship merchandise via any responsible carrier. Seller's responsibility ceases upon acceptance by carrier. Buyer is expected to examine contents of shipments and immediately report any damage to carrier authorities.

Payment terms shall be 30% deposit with order; balance prior to delivery unless otherwise agreed in writing by Seller. Returns of any merchandise may not be made without Seller's written approval, prior to return. Seller shall impose a 20% restocking charge for handling of any returns. All cancellations must be in writing. Cancellations are also subject to a 20% fee.