



Model: DH-65 (230v models)

Electric Woodchip-Burning Stationary Rack Smoker

Approximate Smoker Capacities

(Capacities will vary based on physical shape, weight, and method of loading for each product specified.)

St. Louis Ribs (2.75 lbs)(1.2 kg) each.....65 pieces



(5) rack slides, 5" (127mm) spacing



Standard Features:

- Stainless steel construction; exterior and interior.
- Mineral wool insulated cabinet.
- (2) locking casters (front) and (2) non-locking casters (rear).
- 2" (51mm) flue with variable sized drop-in flue damper.
- Convection fan with 8" (203mm) blower wheel.
- Control with a digital thermostat ((80° to 325°F)(27° to 163°C), allows for selection of cook temperature, cook time, and programming of 30 preset menus).
- 6" (152mm) grease drain pan.
- (5) nickel chrome plated vertical rib racks (see illustration above).
- Single woodchip box.
- 2 1/2" (64mm) steam pan.

Optional Features:

- Right hand door hinge.
- Stainless steel vertical rib racks.

Southern Pride Distributing, LLC
 401 S Mill St
 Alamo, TN 38001
 Phone: 731.696.3175
 Fax: 731.696.3180
 www.southernpride.com

REVISED: September 2016

An ongoing program of product improvement may require us to change specifications without notice.

© 2016 Southern Pride Distributing, LLC

Model: DH-65 (230v models)

Electric Woodchip-Burning Stationary Rack Smoker

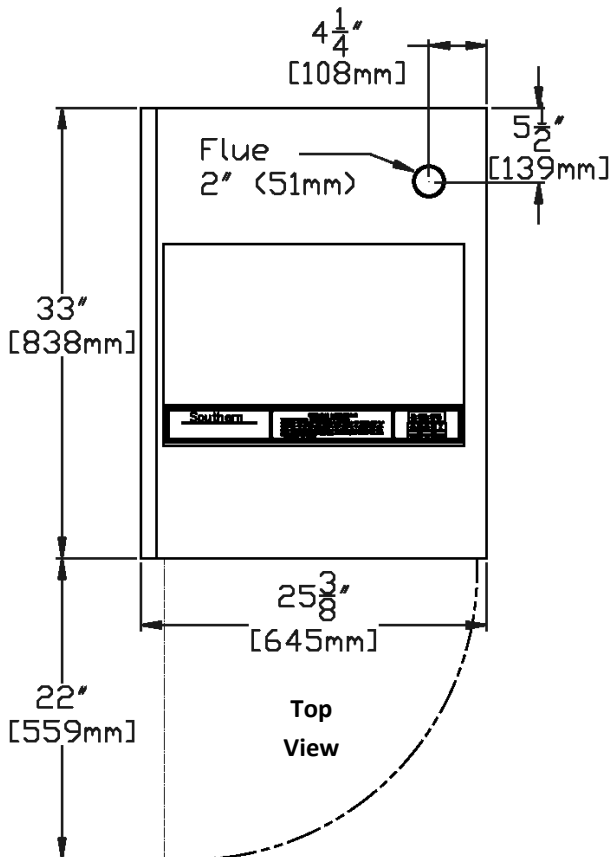
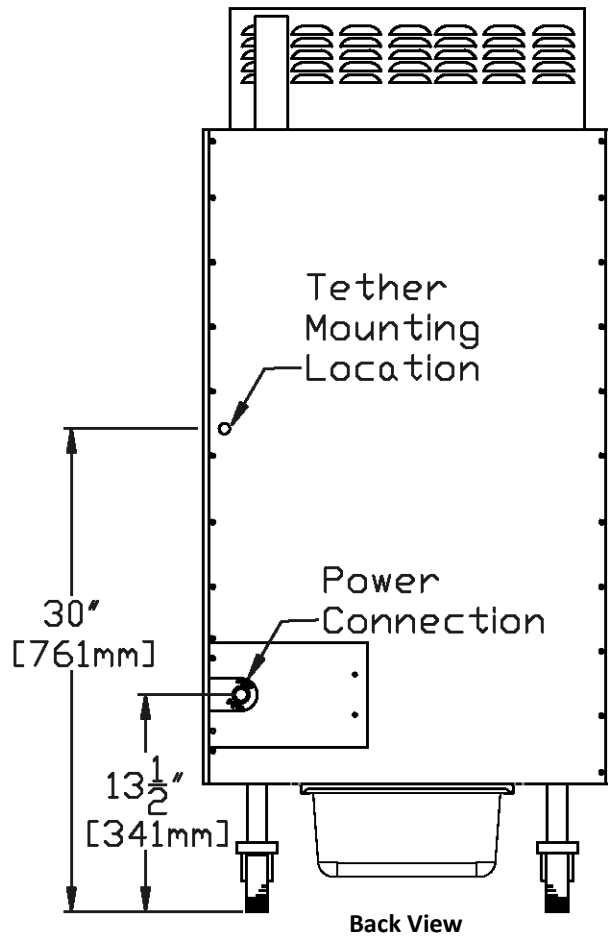
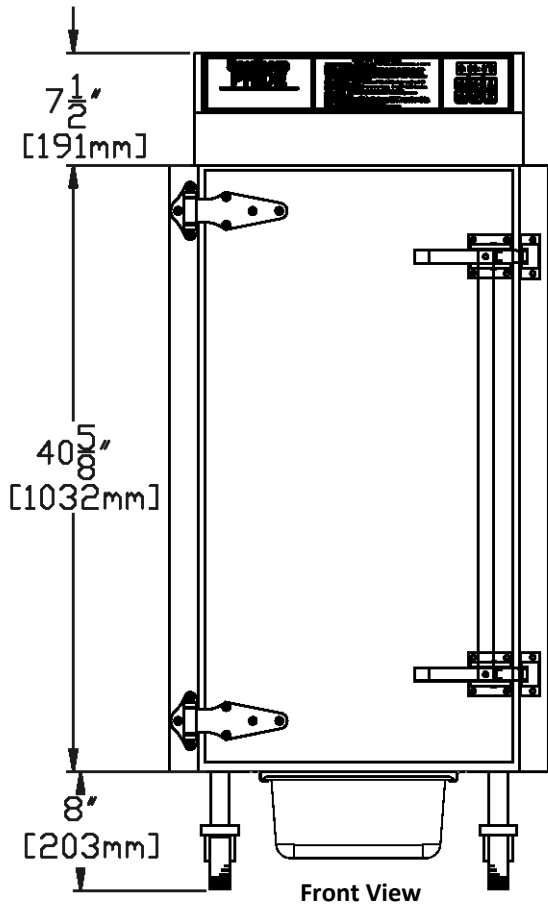

Standard leg locations (center to center) -
19 5/8"W x 25 3/8"D (498 x 645mm)

REQUIREMENTS

ELECTRICAL

230 volt AC

50 hertz, 3 wire (plus ground), 1-phase, 30 amp wiring required

Electrical cord and plug not provided

VENTILATION

The smoker must be vented in accordance with the Owner's Manual and the installation must comply with all relevant local and national codes and in a manner acceptable to the authority having jurisdiction.

SHIPPING (crated) - 540 lbs (245 kg), Class 100

65"H x 50"W x 28"D (1651 x 1270 x 711mm)